

# H 1127 VE

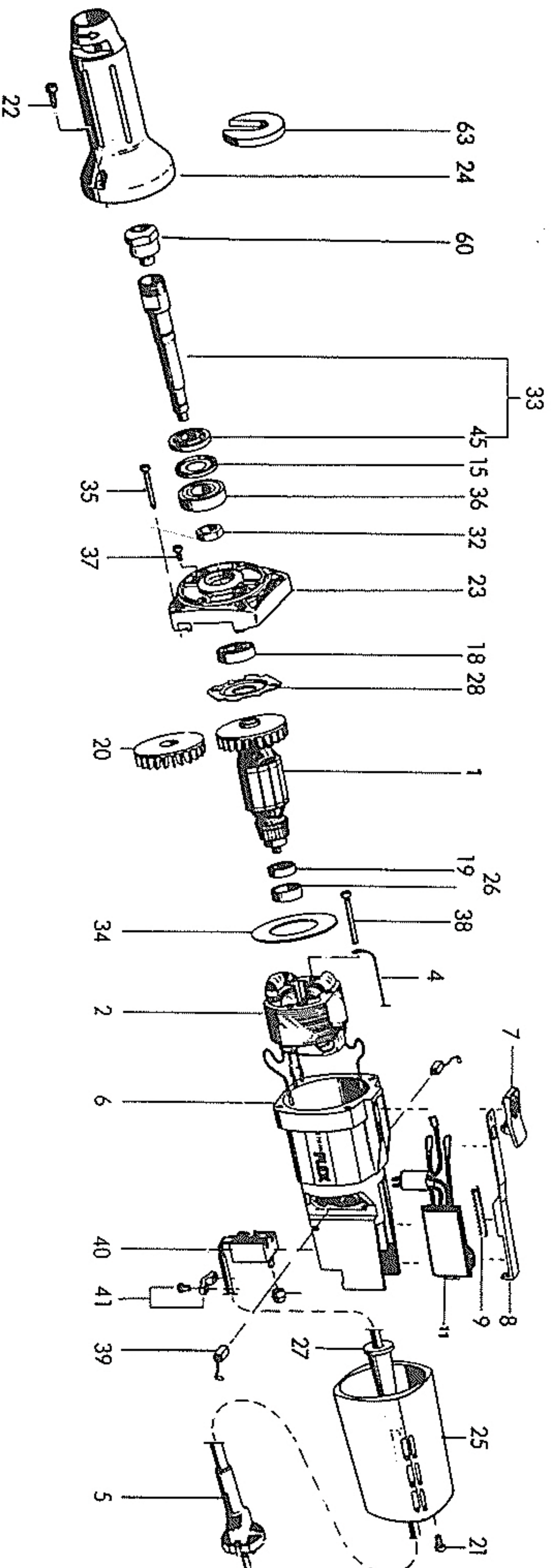

# H 1105 VE

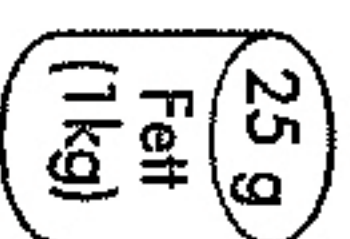
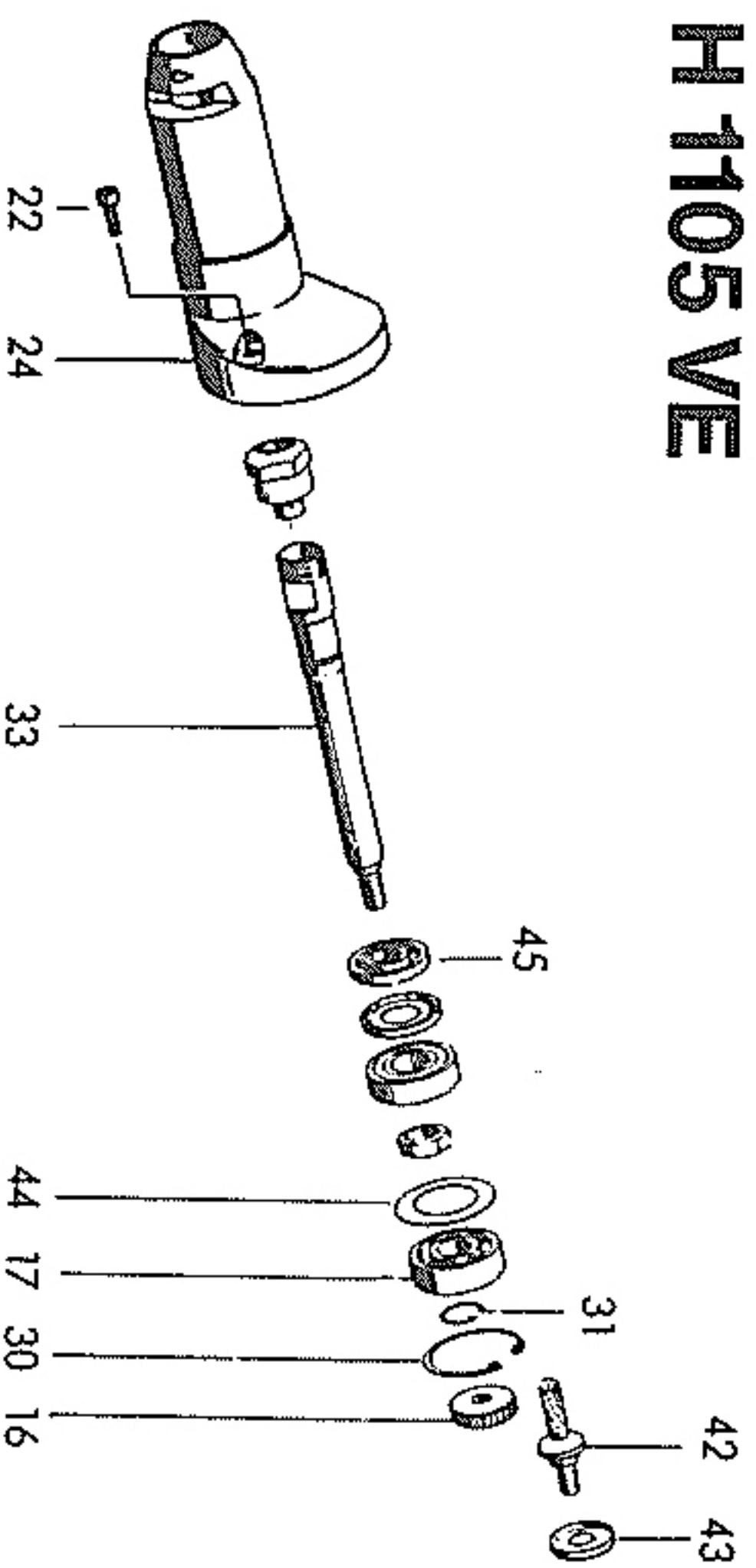

# H 1105 VE/H 1127 VE

Teile-Nr. 269.980 Printed in Germany 01/03

# H 1105 VE, H 1127 VE

DIN Norm	Abmessung mm	Pos	Teil-Nr.	St	Benennung	Designation	Dénomination	Dénominación
					<b>Ersatzteile</b>	<b>Spare parts</b>	<b>Pièces de rechange</b>	<b>Repuestos</b>
		1	159.603	1	Anker (H1127VE)	Armature (H1127VE)	Induit (H1127VE)	Inducido (H1127VE)
		1	270.024	1	Anker (H1105VE)	Armature (H1105VE)	Induit (H1105VE)	Inducido (H1105VE)
		2	292.656	1	Magnetfeld (H1127VE)	Magnetic field (H1127VE)	Champ magnétique (H1127VE)	Campo magnético (H1127VE)
		2	292.699	1	Magnetfeld (H1105VE)	Magnetic field (H1105VE)	Champ magnétique (H1105VE)	Campo magnético (H1105VE)
		4	261.165	1	Litze für Kondensator	Stranded wire for condenser	Toron pur condensateur	Cordon para condensador
	4,0 m	5	236.462	1	Kabel	Cable	Câble	Cable
		6	203.068	1	Motorgehäuse mit Kohlehalter	Motor housing with carbon brush holder	Carter de moteur avec porte charbon	Carcasa motor con porta escob
		7	211.451	1	Schalthebel	Control lever	Levier de commande	Palanca de mando
		8	195.812	1	Schallstange	Control rod	Tige de commande	Barra de mando
		9	195.820	1	Druckfeder	Compressina spring	Ressort de pression	Resorte de compresión
		11	287.687	1	Elektronik	Electronic	Electrique	Electricas
	29x15x0,3	15	121.665	1	Dichtungsring 6002 A	Sealing ring 6002 A	Bague d'étanchéité 6002 A	Anillo de empaquetadura 6002
		16	256.704	1	Zahnrad (H1105VE)	Gear wheel (H1105VE)	Roue dentée (H1105VE)	Rueda dentada (H1105VE)
625	10x35x11	17	192.112	1	Rillenkugellager 6300 RS (H1105VE)	Ball bearing 6300 RS (H1105VE)	Roulement à billes 6300 RS (H1105VE)	Rodamiento de bolas 6300 RS (H1105VE)
625	10x26x8	18	254.442	1	Rillenkugellager 6000 2RSD	Ball bearing 6000 2RSD	Roulement à billes 6000 2RSD	Rodamiento de bolas 6000 2RS
625	7x19x6	19	254.443	1	Rillenkugellager 607 2RSD	Ball bearing 607 2RSD	Roulement à billes 607 2RSD	Rodamiento de bolas 607 2RSD
		20	235.164	1	Windflügel	Fan	Ventilateur	Ventilador
	KT 4x12	21	195.715	2	Schraube	Screw	Vis	Tornillo
912	M 4x14	22	190.330	2	Schraube (H1127VE)	Screw (H1127VE)	Vis (H1127VE)	Tornillo (H1127VE)
912	M 4x20	22	192.082	2	Schraube (H1105VE)	Screw (H1105VE)	Vis (H1105VE)	Tornillo (H1105VE)
		23	157.708	1	Lagerdeckel	Bearing cap	Chapeau de palier	Tapa del cojinete
		24	101.532	1	Kopfstück (H1127VE)	Front case (H1127VE)	Carter de tête (H1127VE)	Carcasa cabezal (H1127VE)
		24	192.074	1	Kopfstück (H1105VE)	Front case (H1105VE)	Carter de tête (H1105VE)	Carcasa cabezal (H1105VE)
		25	213.780	1	Haube	Cover	Capot	Caperuza
		26	257.354	1	Lagerring	Bearing ring	Bague	Anillo
		27	197.041	1	Kabelschutzhülse	Rubber sleeve	Manchon de caoutchouc	Manguito de goma
		28	154.997	1	Lagerdeckel	Bearing cap	Chapeau de palier	Tapa del cojinete
472	35x1,5	30	105.546	1	Sicherungsring (H1105VE)	Locking ring (H1105VE)	Bague d'arrêt (H1105VE)	Anillo de seguridad (H1105VE)
		31	111.406	1	Sicherungsring (H1105VE)	Locking ring (H1105VE)	Bague d'arrêt (H1105VE)	Anillo de seguridad (H1105VE)
		32	235.296	1	Sechskantmutter	Hexagon nut	Ecrou hexagonal	Tuerca hexagonal
		33	234.001	1	Welle (H1127VE)	Shaft (H1127VE)	Arbre (H1127VE)	Eje (H1127VE)
		33	239.828	1	Welle (H1105VE)	Shaft (H1105VE)	Arbre (H1105VE)	Eje (H1105VE)
		34	159.247	1	Luftführung	Air deflection	Guide d'air	Guía de aire
	KT 4x25	35	203.858	4	Schraube	Head screw	Vis	Tornillo
625	15x32x19	36	101.583	1	Rillenkugellager 6002 ZR	Ball bearing 6002 ZR	Roulement à billes 6002 ZR	Rodamiento de bolas 6002 ZR
7985	M 4x6	37	164.283	2	Schraube	Screw	Vis	Tornillo
	KT 4x55	38	196.169	2	Schraube	Screw	Vis	Tornillo
	6,3x7	39	285.994	2	Kohle K 66	Carbon brush K 66	Charbon K 66	Escobilla K 66
		40	195.782	1	Schalter	Switch	Interrupteur	Interruptor
		41	215.074	1	Kabelschleife komplett	Cable clamp complete	Cosse de câble complet	Abrazadera de cable completo
		42	256.705	1	Ritzel (H1105VE)	Pinion (H1105VE)	Pignon (H1105VE)	Pinion (H1105VE)
		43	100.471	1	Dichtungsring 6000 A (H1105VE)	Sealing ring 6000 A (H1105VE)	Bague d'étanchéité 6000 A (H1105VE)	Anillo de empaquetadura 6000 (H1105VE)
		44	192.120	1	Scheibe (H1105VE)	Washer (H1105VE)	Rondelle (H1105VE)	Disco (H1105VE)
		45	121.673	1	Labyrinthring	Sealing ring	Bague d'étanchéité	Anillo de empaquetadura
	6 mm	60	228.656	1	Spannzange mont.	Collet with nut	Pince de serrage avec écrou	Pinza con tuerca
			252.164	1	Griffhaube (H1105VE)	Grip cap	Capôt de tête	Caperuza para
7985	M 4x8		258.573	2	Schraube für Griffhaube (H1105VE)	Screw for grip cap	Vis	Tornillo
			255.691		25 g Getriebefett (VE 1kg, H1105VE)	Gear grease (H1105VE)	Graisse pour engrenage (H1105VE)	Grasa para engranajes (H1105)
					<b>Grundausstattung</b>	<b>Standard components</b>	<b>Équipement de base</b>	<b>Equipo básico</b>
894	SW 19		104.914	1	Einmalschlüssel	Fork spanner	Clé fourche	Llave de una boca
	SW 14	63	254.917	1	Anhafteschlüssel	Holding spanner	Clé creuse coudée	Llave de parada
					<b>Sonderzubehör auf Wunsch</b>	<b>Special accessories upon requirements:</b>	<b>Accessoires spéciaux sur demande:</b>	<b>Accesorios especiales a deseo:</b>
		60	229.741	1	Spannzange mit Mutter 3 mm	Collet with nut 3 mm	Pince de serrage avec écrou 3 mm	Pinza con tuerca 3 mm
		60	229.784	1	Spannzange mit Mutter 1/8"	Collet with nut 1/8"	Pince de serrage avec écrou 1/8"	Pinza con tuerca 1/8"
		60	229.776	1	Spannzange mit Mutter 1/4"	Collet with nut 1/4"	Pince de serrage avec écrou 1/4"	Pinza con tuerca 1/4"
		60	229.768	1	Spannzange mit Mutter 8 mm	Collet with nut 8 mm	Pince de serrage avec écrou 8 mm	Pinza con tuerca 8 mm